



EL series single system

EL-60 / EL-80-15 / EL-80-17
EL-100 / EL-120

Product characteristics

- Integrated overload protection
- Protective switch inclusive
- Optional with fault alarm lamp and integrated signal cable
- Connecting hose included in delivery

Dimensions

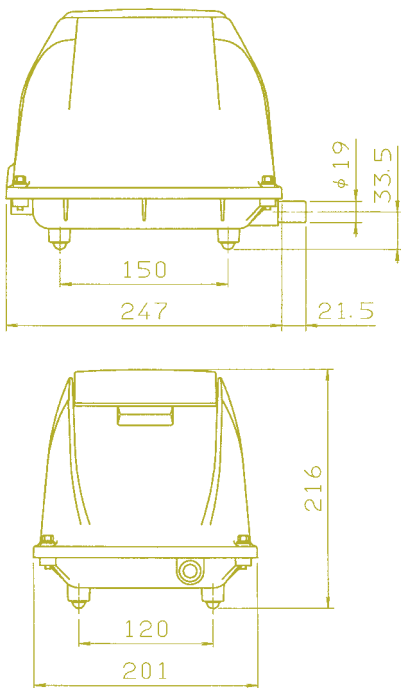

Technical data

Model			EL-60	EL-80-15	EL-80-17	EL-100	EL-120
Air flow ¹⁾	l/min	0 mbar	105	127	142	152	190
		50 mbar	96	115	131	142	176
		100 mbar	83	102	113	130	156
		150 mbar	68	87	95	112	138
		200 mbar	54	73	77	94	123
		250 mbar	40	56	59	77	105
Voltage/Frequency	V/Hz		230/50	230/50	230/50	230/50	230/50
Power consumption	W	200 mbar	44	74	71	92	120
Noise level	dB(A)		36	40	40	42	55
Dimensions	mm	L x W x H	268.5 x 201 x 216				
Connection	mm	Ø outside	19	19	19	19	19
Net weight	kg		8.5	8.5	8.5	8.5	9

¹⁾ Product performance may vary +/- 10% from performance curves.

Performance data

Optimal operating span

